

# GENERAC®

MODELS: 005796-0 (XG6500), 005797-0 (XG7000),  
005798-0 (XG7000E), 005800-0 (XG8000),  
005747-0 (XG8000E)

# Owner's Manual

## XG Series 6,500-8,000 Watt Portable Generator

**2 YEAR**  
LIMITED  
WARRANTY

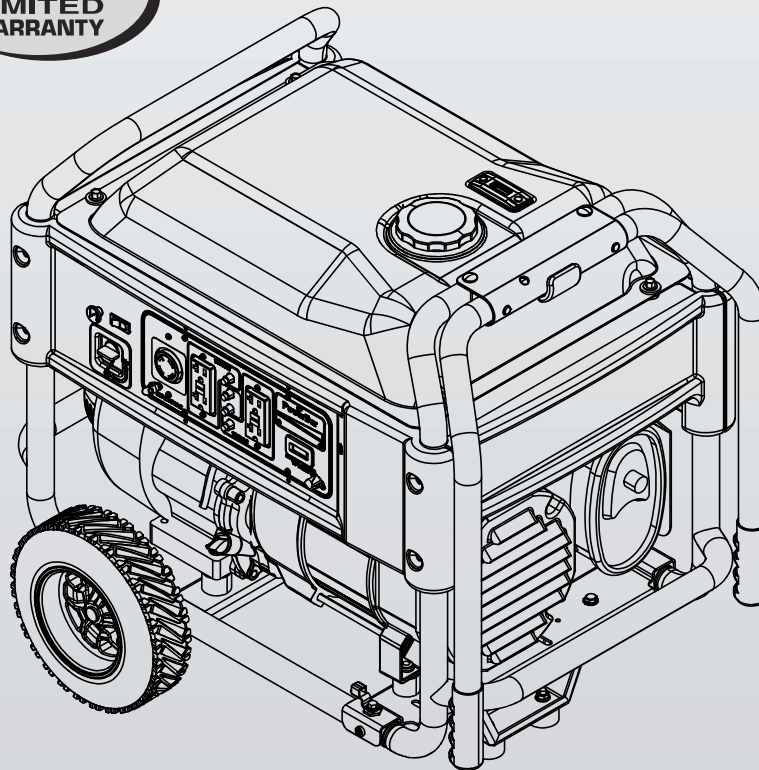

[www.generac.com](http://www.generac.com) or 1-888-436-3722

# Table of Contents

<b>Introduction.....</b>	<b>1</b>	<b>Maintenance .....</b>	<b>11</b>
<b>Read this Manual Thoroughly.....</b>	<b>1</b>	3.1 Maintenance Schedule .....	11
<b>Safety Rules .....</b>	<b>1</b>	3.2 Product Specifications.....	11
Standards Index .....	3	3.2.1 Generator Specifications .....	11
<b>General Information.....</b>	<b>4</b>	3.2.2 Engine Specifications .....	12
1.1 Unpacking.....	4	3.2.3 Emissions Information .....	12
1.1.1 Accessory Box .....	4	3.3 General Recommendations.....	12
1.2 Assembly.....	4	3.3.1 Generator Maintenance .....	12
1.2.1 Assembling the Wheel Kit and Frame Foot.....	4	3.3.2 To Clean the Generator.....	13
<b>Operation .....</b>	<b>5</b>	3.3.3 Engine Maintenance.....	13
2.1 Know the Generator .....	5	3.3.4 Checking Oil Level .....	13
2.1.1 Battery Connection (XG7000E & XG8000E) .....	6	3.3.5 Changing the Oil and Oil Filter .....	13
2.2 Hourmeter.....	6	3.3.6 Replacing the Spark Plug .....	13
2.3 Cord Sets and Connection Plugs .....	6	3.4 Service Air Cleaner.....	13
2.3.1 120 VAC, 20 Amp, GFCI Duplex Receptacle .....	6	3.5 Clean Spark Arrestor Screen.....	14
2.3.2 120/240 VAC, 30 Amp Receptacle.....	6	3.6 General .....	14
2.4 How to Use the Generator .....	7	3.7 Long Term Storage.....	14
2.4.1 System Ground.....	7	3.8 Other Storage Tips .....	15
2.4.2 Grounding the Generator .....	7	<b>Battery Service .....</b>	<b>15</b>
2.4.3 Neutral to Frame Grounding .....	8	4.1 Battery Replacement (XG7000E & XG8000E) .....	15
2.4.4 Connecting Electrical Loads .....	8	<b>Troubleshooting .....</b>	<b>16</b>
2.5 Don't Overload the Generator.....	8	5.1 Troubleshooting Guide.....	16
2.6 Wattage Reference Guide .....	8	<b>Notes .....</b>	<b>17</b>
2.7 Before Starting the Generator .....	9	<b>Warranty .....</b>	<b>18</b>
2.7.1 Adding Engine Oil .....	9		
2.7.2 Adding Gasoline.....	9		
2.8 To Start the Engine.....	10		
2.8.1 Manual (Recoil) Starting .....	10		
2.8.2 Electric Starting (XG7000E & XG8000E) .....	11		
2.9 Stopping the Engine .....	11		
2.10 Low Oil Pressure Shutdown System.....	11		
2.10.1 Restarting.....	11		
2.11 Charging a Battery .....	11		

## INTRODUCTION

Thank you for purchasing this model by Generac Power Systems, Inc. This model is a compact, high performance, air-cooled, engine driven generator designed to supply electrical power to operate electrical loads where no utility power is available or in place of utility due to a power outage.

## READ THIS MANUAL THOROUGHLY

If any portion of this manual is not understood, contact the nearest Authorized Dealer for starting, operating and servicing procedures.

The operator is responsible for proper and safe use of the equipment. We strongly recommend that the operator read this manual and thoroughly understand all instructions before using the equipment. We also strongly recommend instructing other users to properly start and operate the unit. This prepares them if they need to operate the equipment in an emergency.

The generator can operate safely, efficiently and reliably only if it is properly located, operated and maintained. Before operating or servicing the generator:

- Become familiar with and strictly adhere to all local, state and national codes and regulations.
- Study all safety warnings in this manual and on the product carefully.
- Become familiar with this manual and the unit before use.

The manufacturer cannot anticipate every possible circumstance that might involve a hazard. The warnings in this manual, and on tags and decals affixed to the unit are, therefore, not all inclusive. If using a procedure, work method or operating technique that the manufacturer does not specifically recommend, ensure that it is safe for others. Also make sure the procedure, work method or operating technique utilized does not render the generator unsafe.

THE INFORMATION CONTAINED HEREIN WAS BASED ON MACHINES IN PRODUCTION AT THE TIME OF PUBLICATION. GENERAC RESERVES THE RIGHT TO MODIFY THIS MANUAL AT ANY TIME.

## SAFETY RULES

Throughout this publication, and on tags and decals affixed to the generator, DANGER, WARNING, CAUTION and NOTE blocks are used to alert personnel to special instructions about a particular operation that may be hazardous if performed incorrectly or carelessly. Observe them carefully. Their definitions are as follows:

### **DANGER!**

**INDICATES A HAZARDOUS SITUATION OR ACTION WHICH, IF NOT AVOIDED, WILL RESULT IN DEATH OR SERIOUS INJURY.**

### **WARNING!**

**Indicates a hazardous situation or action which, if not avoided, could result in death or serious injury.**

### **CAUTION!**

**Indicates a hazardous situation or action which, if not avoided, could result in minor or moderate injury.**

#### NOTE:

**Notes contain additional information important to a procedure and will be found within the regular text body of this manual.**

These safety warnings cannot eliminate the hazards that they indicate. Common sense and strict compliance with the special instructions while performing the action or service are essential to preventing accidents.

Four commonly used safety symbols accompany the **DANGER**, **WARNING** and **CAUTION** blocks. The type of information each indicates is as follows:

 **This symbol points out important safety information that, if not followed, could endanger personal safety and/or property of others.**

 **This symbol points out potential explosion hazard.**

 **This symbol points out potential fire hazard.**

 **This symbol points out potential electrical shock hazard.**

## GENERAL HAZARDS

- Never operate in an enclosed area or indoors.
- For safety reasons, the manufacturer recommends that the maintenance of this equipment is carried out by an Authorized Dealer. Inspect the generator regularly, and contact the nearest Authorized Dealer for parts needing repair or replacement.
- Operate generator only on level surfaces and where it will not be exposed to excessive moisture, dirt, dust or corrosive vapors.
- Keep hands, feet, clothing, etc., away from drive belts, fans, and other moving parts. Never remove any fan guard or shield while the unit is operating.
- Certain parts of the generator get extremely hot during operation. Keep clear of the generator until it has cooled to avoid severe burns.
- Do NOT operate generator in the rain.
- Do not alter the construction of the generator or change controls which might create an unsafe operating condition.
- Never start or stop the unit with electrical loads connected to receptacles AND with connected devices turned ON. Start the engine and let it stabilize before connecting electrical loads. Disconnect all electrical loads before shutting down the generator.
- Do not insert objects through unit's cooling slots.
- When working on this equipment, remain alert at all times. Never work on the equipment when physically or mentally fatigued.

## Safety Rules

- Never use the generator or any of its parts as a step. Stepping on the unit can stress and break parts, and may result in dangerous operating conditions from leaking exhaust gases, fuel leakage, oil leakage, etc.
- On electric start models, disconnect the POSITIVE (+) battery cable from the engine starter OR the NEGATIVE (-) battery cable from the battery terminal, whichever is easier, before transporting the generator.

### NOTE:

***This generator is equipped with a spark arrestor muffler. The spark arrestor must be maintained in effective working order by the owner/ operator. In the State of California, a spark arrestor is required by law (Section 4442 of the California Public Resources Code). Other states may have similar laws. Federal laws apply on federal lands.***

## EXHAUST & LOCATION HAZARDS

- **Never operate in an enclosed area or indoors! NEVER use in the home, or in partly enclosed areas such as garages, even if doors and windows are open! ONLY use outdoors and far from open windows, doors, vents, and in an area that will not accumulate deadly exhaust.**

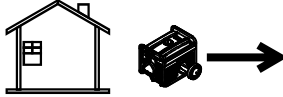
 <b>DANGER</b>	
<b>Using a generator indoors CAN KILL YOU IN MINUTES.</b>	
<b>Generator exhaust contains carbon monoxide. This is a poison you cannot see or smell.</b>	
	
<b>NEVER use inside a home or garage, EVEN IF doors and windows are open.</b>	
	<b>Only use OUTSIDE and far away from windows, doors, and vents.</b>

- The engine exhaust fumes contain carbon monoxide, which you cannot see or smell. This poisonous gas, if breathed in sufficient concentrations, can cause unconsciousness or even death.
- Adequate, unobstructed flow of cooling and ventilating air is critical to correct generator operation. Do not alter the installation or permit even partial blockage of ventilation provisions, as this can seriously affect safe operation of the generator. The generator **MUST** be operated outdoors.
- This exhaust system must be properly maintained. Do nothing that might render the exhaust system unsafe or in non-compliance with any local codes and/or standards.
- Always use a battery operated carbon monoxide alarm indoors, installed according to the manufacturer's instructions.
- If you start to feel sick, dizzy, or weak after the generator has been running, move to fresh air **IMMEDIATELY**. See a doctor, as you could have carbon monoxide poisoning.

## ELECTRICAL HAZARDS

- The generator produces dangerously high voltage when in operation. Avoid contact with bare wires, terminals, connections, etc., while the unit is running, even on equipment connected to the generator. Ensure all appropriate covers, guards and barriers are in place before operating the generator.
- Never handle any kind of electrical cord or device while standing in water, while barefoot or while hands or feet are wet. **DANGEROUS ELECTRICAL SHOCK MAY RESULT.**
- The National Electric Code (NEC) requires the frame and external electrically conductive parts of the generator be properly connected to an approved earth ground. Local electrical codes may also require proper grounding of the generator. Consult with a local electrician for grounding requirements in the area.
- Use a ground fault circuit interrupter in any damp or highly conductive area (such as metal decking or steel work).
- Do not use worn, bare, frayed or otherwise damaged electrical cord sets with the generator.
- Before performing any maintenance on the generator, disconnect the engine starting battery (if equipped) to prevent accidental start up. Disconnect the cable from the battery post indicated by a NEGATIVE, NEG or (-) first. Reconnect that cable last.
- In case of accident caused by electric shock, immediately shut down the source of electrical power. If this is not possible, attempt to free the victim from the live conductor. **AVOID DIRECT CONTACT WITH THE VICTIM.** Use a non-conducting implement, such as a rope or board, to free the victim from the live conductor. If the victim is unconscious, apply first aid and get immediate medical help.

## FIRE HAZARDS

- **Gasoline is highly FLAMMABLE and its vapors are EXPLOSIVE. Do not permit smoking, open flames, sparks or heat in the vicinity while handling gasoline.**
- Never add fuel while unit is running or hot. Allow engine to cool completely before adding fuel.
- **Never fill fuel tank indoors.** Comply with all laws regulating storage and handling of gasoline.
- **Do not overfill the fuel tank. Always allow room for fuel expansion.** If tank is over-filled, fuel can overflow onto a hot engine and cause FIRE or an EXPLOSION. Never store generator with fuel in tank where gasoline vapors might reach an open flame, spark or pilot light (as on a furnace, water heater or clothes dryer). FIRE or EXPLOSION may result. Allow unit to cool entirely before storage.
- Wipe up any fuel or oil spills immediately. Ensure that no combustible materials are left on or near the generator. Keep the area surrounding the generator clean and free from debris and keep a clearance of five (5) feet on all side to allow for proper ventilation of the generator.

- Do not insert objects through unit's cooling slots.
- **Do not** operate the generator if connected electrical devices overheat, if electrical output is lost, if engine or generator sparks or if flames or smoke are observed while unit is running.
- Keep a fire extinguisher near the generator at all times.

MODEL NO:	
SERIAL NO:	

## STANDARDS INDEX

In the absence of pertinent standards, codes, regulations and laws, the published information listed below may be used as a guideline for operation of this equipment. Always reference the latest revision available for the standards listed.

1. NFPA No. 70, NFPA HANDBOOK OF NATIONAL ELECTRIC CODE.
2. Article X, NATIONAL BUILDING CODE, available from the American Insurance Association, 85 John Street, New York, N.Y. 10038.
3. AGRICULTURAL WIRING HANDBOOK, available from the Food and Energy Council, 909 University Avenue, Columbia, MO 65201.
4. ASAE EP-3634, INSTALLATION AND MAINTENANCE OF FARM STANDBY ELECTRICAL SYSTEMS, available from the American Society of Agricultural Engineers, 2950 Niles Road, St. Joseph, MI 49085.

## Generator Identification

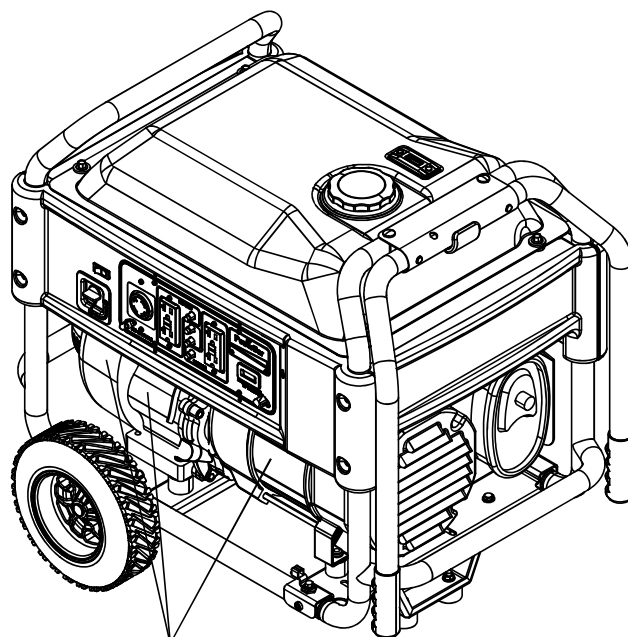

**Unit ID  
Locations**

### CALIFORNIA PROPOSITION 65 WARNING

Engine exhaust and some of its constituents are known to the State of California to cause cancer, birth defects and other reproductive harm.

### CALIFORNIA PROPOSITION 65 WARNING

This product contains or emits chemicals known to the State of California to cause cancer, birth defects and other reproductive harm.

# General Information

## 1.1 UNPACKING

- Remove all packaging material.
- Remove separate accessory box.
- Remove carton off the generator.

### 1.1.1 ACCESSORY BOX

Check all contents (Figure 1). If any parts are missing or damaged locate an authorized dealer at 1-888-775-6937.

Contents include:

- |                                  |                              |
|----------------------------------|------------------------------|
| • 2 – Axle Pins                  | • Oil Filter                 |
| • 2 – Wheel Spacers              | • Air Filter                 |
| • 2 – Hair Pins                  | • Spark Plug                 |
| • 2 – Wheels                     | • Spark Plug Wrench          |
| • 1 – Frame Foot                 | • Shop Towel                 |
| • 2 – Frame Bolts                | • 2 – Frame Washers          |
| • 2 – Vibration Mounts           | • Oil Funnel                 |
| • 4 – Flange Nuts                | 12 Volt Adaptor Plug Charger |
| • 2 – 1 Quart SAE 30 Oil Bottles |                              |

Figure 1 – Accessory Boxes

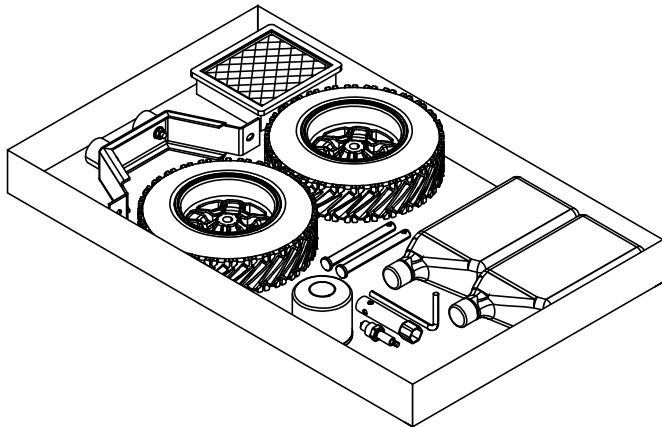

## 1.2 ASSEMBLY

Read entire Owner's Manual before attempting to assemble or operate the generator. The generator requires some assembly prior to using it. If problems arise when assembling the generator, please call the Generator Helpline at 1-888-775-6937.

### 1.2.1 ASSEMBLING THE WHEEL KIT AND FRAME FOOT

The wheel kit is designed to greatly improve the portability of the generator. You will need the following tools to install the wheel kit: Pliers, 1/2" (13mm) wrench and a socket wrench with a 1/2" (13mm) socket.

**NOTE:**

**The wheel kit is not intended for over-the-road use.**

- Refer to Figure 2 and install the wheel kit and frame foot as follows:
- Slide the Axle Pin through the Wheel, Wheel Spacer (Washer) and the Frame.
- Install the Hair Pin to the Axle Pin to secure the wheel. Repeat for the opposite side.
- Secure the Vibration Mounts to the Frame Foot with the included locking nuts.
- To install the Frame Foot, install the Frame Bolts through the Frame Washers, Frame and Frame foot. Secure with the locking nuts.

Figure 2 – Wheel and Foot Assembly

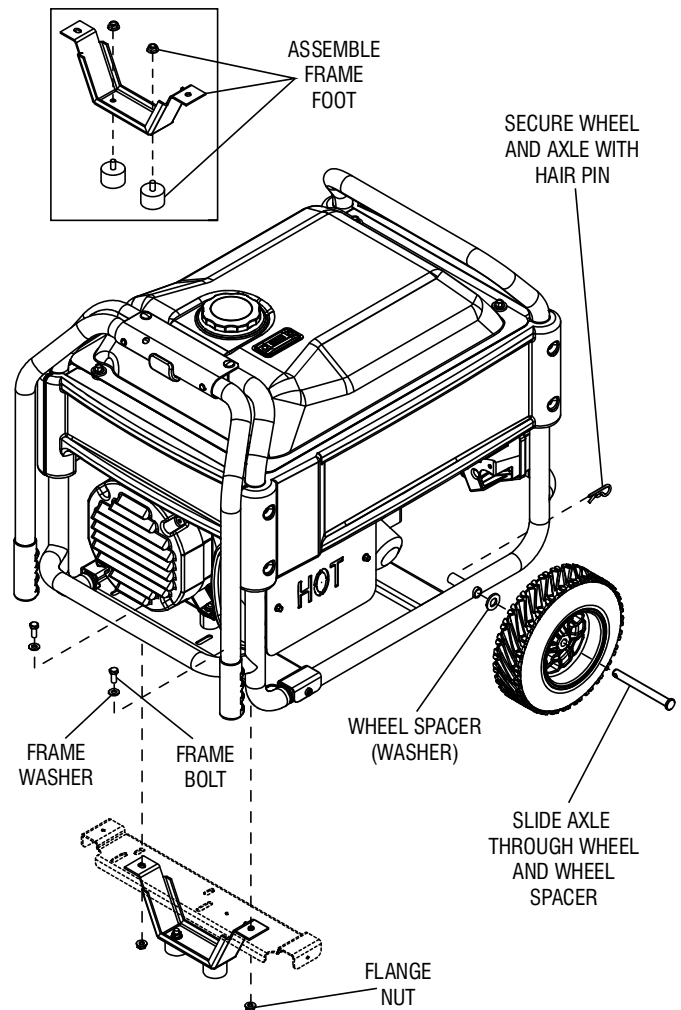

## 2.1 KNOW THE GENERATOR

Read the entire Owner's Manual and Safety Rules before operating this generator.

Compare the generator to Figures 3 through 6 to become familiarized with the locations of various controls and adjustments. Save this manual for future reference.

1. **Choke Knob** – Used when starting a cold engine (Pull/Push).
2. **Engine Switch** – Controls the operation of the generator. On electric start models the switch is Start/Run/Stop. On recoil start models the switch is On/Off.
3. **Fuel Shut Off** – Valve between fuel tank and carburetor. Turn off and run carburetor out of fuel for extended storage.
4. **Panel LED's** – Provide illumination of the control panel while the generator is operating.
5. **120/240 Volt AC, 30 Amp Locking Receptacle** – Supplies electrical power for the operation of 120 and/or 240 Volt AC, 30 Amp, single-phase, 60 Hz, electrical lighting, appliance, tool and motor loads.
6. **120 Volt AC, 20 Amp, GFCI Duplex Receptacle** – Supplies electrical power for the operation of 120 Volt AC, 20 Amp, single-phase, 60 Hz electrical lighting, appliance, tool and motor loads. It also provides protection with an Integral Ground Fault Circuit Interrupter, complete with a press to "Test" and "Reset" button.
7. **Circuit Breakers (AC)** – Each 20 Amp receptacle is provided with a push-to-reset circuit breaker to protect the generator against electrical overload.
8. **Circuit Breakers (AC)** – The 30 Amp receptacle is protected with a pair of push-to-reset circuit breakers to protect the generator against electrical overload.
9. **PowerBar** – Indicates the amount of power being used from the generator; each section is approximately 25%
10. **Hourmeter** – Provides operating hours for Service Intervals.
11. **Battery Charger Input (Electric Start Models)** – This receptacle allows the capability to recharge the 12 VDC engine starting battery with the 12 Volt Adaptor Plug Charger. The battery is protected by a 1.50 Amp in-line fuse which is inside the control panel.
12. **Fuel Tank** – Tank holds 9 U.S. gallons of fuel.
13. **Fuel Gauge** – Shows fuel level in tank.
14. **Handles** – Pivot and retract for storage. Press the spring-loaded button to move handles.
15. **Oil Fill** – Check oil level and add oil here.
16. **Grounding Lug** – Ground the generator to an approved earth ground here. See "Grounding the Generator" for details.
17. **Muffler** – Includes the spark arrestor and quiets the engine.
18. **Spark Plug Location** – The spark plug ignites the Air/Fuel Mixture (Side panel must be removed).
19. **Engine Oil Filter** – Filters engine oil; see Section 3.1 for the proper service intervals.
20. **Air Cleaner** – Filters intake air as it is drawn into the engine.
21. **Oil Drain** – Drain valve to remove used oil from the engine crankcase.
22. **Recoil Starter** – Use to start engine manually.

Figure 3 – Generator Locations

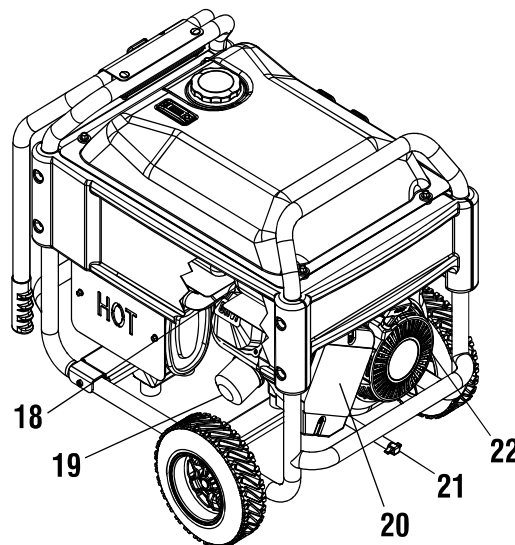
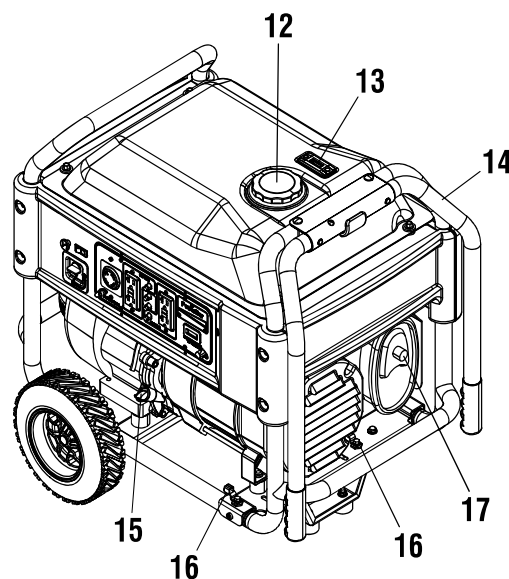
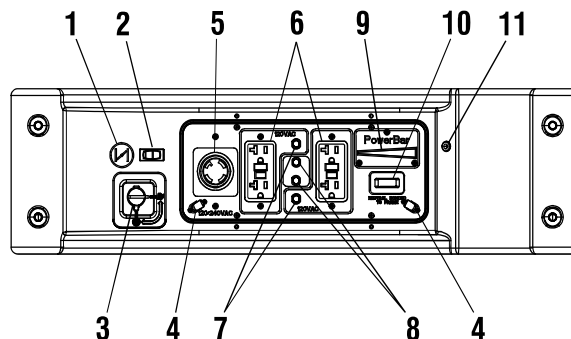



# Operation

## 2.1.1 BATTERY CONNECTION (XG7000E & XG8000E)

### NOTE:

The battery shipped with the generator has been fully charged.

**A battery may lose some of its charge when not in use for prolonged periods of time. If the battery is unable to crank the engine, plug in the 12V charger included in the accessory box (see the Charging the Battery section). RUNNING THE GENERATOR DOES NOT CHARGE THE BATTERY.**

The positive battery wire was deliberately left detached for shipping. To operate the unit, attach this wire to the terminal on the starter motor as shown. Do not overtighten. Slide the attached rubber boot over the starter terminal. See Figure 4.

**Figure 4 – Battery Connection**

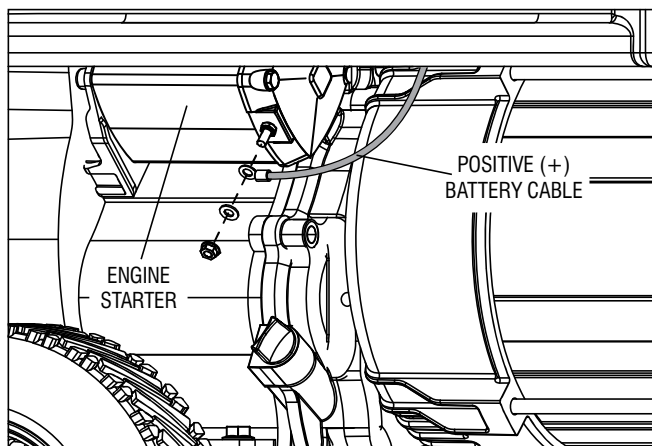

## 2.2 HOURMETER

The Hourmeter tracks hours of operation for scheduled maintenance:

There will be a one time break in "CHG OIL" message that flashes with the elapsed time in hours and tenths after the first 30 hours of operation.

This message will actually begin flashing at 29 hours and disable itself at 31 hours providing a two hour window to perform the service.

There will be a subsequent "CHG OIL" message every 100 hours. The message will flash one hour before and one hour after each 100 hour interval, again providing a two hour window to perform service.

Every 200 hours the "SVC" icon on the lower left hand corner of the display will flash. The message will flash one hour before and one hour after each 200 hour interval providing a two hour window to perform service.

When the hour meter is in the Flash Alert mode, the maintenance message will always alternate with elapsed time in hours and tenths. The hours will flash four times, then alternate with the maintenance message four times until the meter resets itself.

- 100 hours - CHG OIL — Oil Change Interval (Every 100 hrs)
- 200 hours - SVC — Air Filter Interval (Every 200 hrs)

## 2.3 CORD SETS AND CONNECTION PLUGS

### 2.3.1 120 VAC, 20 AMP, GFCI DUPLEX RECEPTACLE

This is a 120 Volt outlet protected against overload by a 20 Amp push-to-reset circuit breaker (Figure 5). Use each socket to power 120 Volt AC, single phase, 60 Hz electrical loads requiring up to a combined 2400 watts (2.4 kW) or 20 Amps of current. Use only high quality, well-insulated, 3-wire grounded cord sets rated for 125 Volts at 20 Amps (or greater).

Keep extension cords as short as possible, preferably less than 15 feet long, to prevent voltage drop and possible overheating of wires.

### 2.3.2 120/240 VAC, 30 AMP RECEPTACLE

Use a NEMA L14-30 plug with this receptacle (rotate to lock/unlock). Connect a suitable 4-wire grounded cord set to the plug and to the desired load. The cord set should be rated for 250 Volts AC at 30 Amps (or greater) (Figure 5).

Use this receptacle to operate 120 Volt AC, 60 Hz, single phase loads requiring up to 3600 watts (3.6 kW) of power at 30 Amps or 240 Volt AC, 60 Hz, single phase loads requiring 6,500 to 8000 watts of power, depending on the model. The outlet is protected by a 30 Amp circuit breaker.

**Figure 5 – Generator Receptacles**

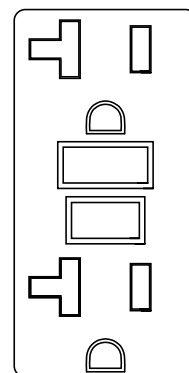

**120 VAC 20A  
GFCI RECEPTACLE**

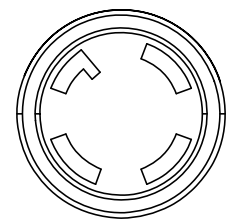

**120/240 VAC 30A  
RECEPTACLE**



## 2.4 HOW TO USE THE GENERATOR

If there are any problems operating the generator, please call the generator helpline at 1-888-436-3722.

### ⚠ DANGER!

- ⚠ **Never operate in an enclosed area or indoors! NEVER use in the home, or in partly enclosed areas such as garages, even if doors and windows are open! ONLY use outdoors and far from open windows, doors, vents, and in an area that will not accumulate deadly exhaust.**
- ⚠ **The engine exhaust fumes contain carbon monoxide, which you cannot see or smell. This poisonous gas, if breathed in sufficient concentrations, can cause unconsciousness or even death.**
- ⚠ **Adequate, unobstructed flow of cooling and ventilating air is critical to correct generator operation. Do not alter the installation or permit even partial blockage of ventilation provisions, as this can seriously affect safe operation of the generator. The generator MUST be operated outdoors.**
- ⚠ **This exhaust system must be properly maintained. Do nothing that might render the exhaust system unsafe or in noncompliance with any local codes and/or standards.**
- ⚠ **The manufacturer recommends installing a battery operated carbon monoxide alarm indoors, according to the manufacturers instructions.**

**⚠ DANGER**

Using a generator indoors CAN KILL YOU IN MINUTES.

Generator exhaust contains carbon monoxide. This is a poison you cannot see or smell.

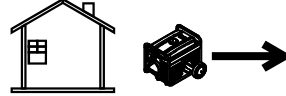
 <p><b>NEVER</b> use inside a home or garage, <b>EVEN IF</b> doors and windows are open.</p>	 <p>Only use <b>OUTSIDE</b> and far away from windows, doors, and vents.</p>
---	---

### 2.4.1 SYSTEM GROUND

The generator has a system ground that connects the generator frame components to the ground terminals on the AC output receptacles. The system ground is bonded to the AC neutral wire in the generator control panel via a jumper wire.

### Special Requirements

There may be Federal or State Occupational Safety and Health Administration (OSHA) regulations, local codes, or ordinances that apply to the intended use of the generator.

Please consult a qualified electrician, electrical inspector, or the local agency having jurisdiction:

- In some areas, generators are required to be registered with local utility companies.
- If the generator is used at a construction site, there may be additional regulations which must be observed.

### Connecting to a Building's Electrical System

Connections for standby power to a building's electrical system must be made by a qualified electrician. The connection must isolate the generator power from utility power or other alternative power sources and must comply with all applicable laws and electrical codes.

### 2.4.2 GROUNDING THE GENERATOR

#### ⚠ WARNING!

- ⚠ **The National Electrical Code requires that the frame and external electrically conductive parts of this generator be properly connected to an approved earth ground.**

Local electrical codes may also require proper grounding of the unit (Figure 6). For that purpose, connecting a No. 10 AWG (American Wire Gauge) stranded copper wire to the grounding lug and to an earth-driven copper or brass grounding rod (electrode) provides adequate protection against electrical shock. However, local codes may vary widely. **Consult with a local electrician for grounding requirements in the area.**

**Proper grounding of the generator will help prevent electrical shock** in the event of a ground fault condition in the generator or in connected electrical devices. Proper grounding also helps dissipate static electricity, which often builds up in ungrounded devices.

*Figure 6 – Generator Ground Location*

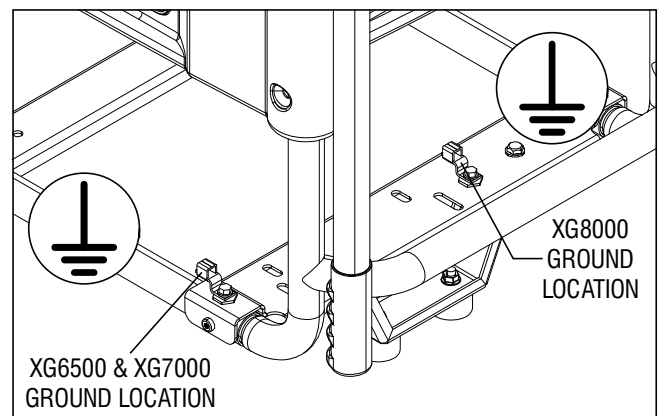

# Operation

## 2.4.3 NEUTRAL TO FRAME GROUNDING

If service work is performed on the alternator, **DO NOT** discard the white jumper wires from the terminal block to the alternator ground, located on the rear bearing carrier. Always make sure the wires are properly connected before using the generator after alternator service work is done (Figure 7).

### **⚠ DANGER!**

**⚠ Failure to reconnect these wires may create a potential shock hazard when the generator is running!**

Figure 7 – Neutral to Frame Ground

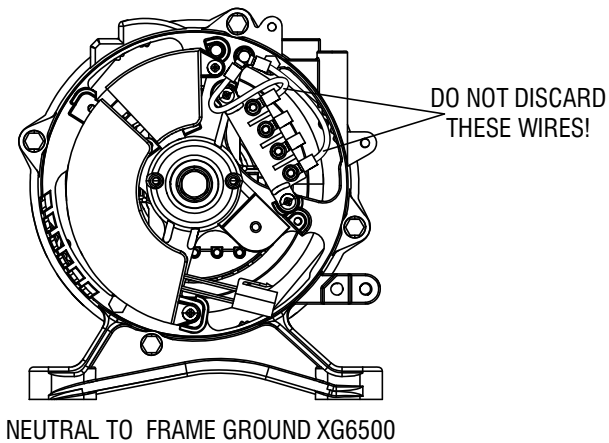
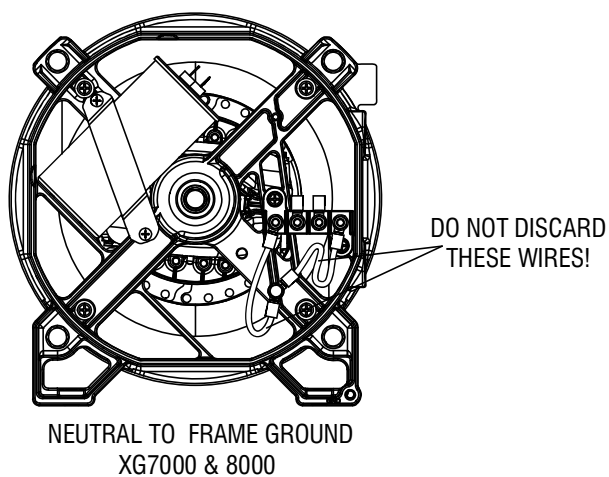

## 2.4.3 CONNECTING ELECTRICAL LOADS

**DO NOT** connect 240 Volt loads to 120 Volt receptacles.

**DO NOT** connect 3 phase loads to the generator.

**DO NOT** connect 50 Hz loads to the generator.

- Let engine stabilize and warm up for a few minutes after starting.
- Plug in and turn on the desired 120 or 240 Volt AC, single phase, 60 Hz electrical loads.

- Add up the rated watts (or amps) of all loads to be connected at one time. This total should no be greater than (a) the rated wattage/amperage capacity of the generator or (b) circuit breaker rating of the receptacle supplying the power. See "Don't Overload the Generator"

## 2.5 DON'T OVERLOAD THE GENERATOR

Overloading a generator in excess of its rated wattage capacity can result in damage to the generator and to connected electrical devices. Observe the following to prevent overloading the unit:

- Add up the total wattage of all electrical devices to be connected at one time. This total should NOT be greater than the generator's wattage capacity.
- The rated wattage of lights can be taken from light bulbs. The rated wattage of tools, appliances and motors can usually be found on a data label or decal affixed to the device.
- If the appliance, tool or motor does not give wattage, multiply volts times ampere rating to determine watts (volts x amps = watts).
- Some electric motors, such as induction types, require about three times more watts of power for starting than for running. This surge of power lasts only a few seconds when starting such motors. Make sure to allow for high starting wattage when selecting electrical devices to connect to the generator:
  1. Figure the watts needed to start the largest motor.
  2. Add to that figure the running watts of all other connected loads.

The Wattage Reference Guide is provided to assist in determining how many items the generator can operate at one time.

### NOTE:

*All figures are approximate. See data label on appliance for wattage requirements.*

## 2.6 WATTAGE REFERENCE GUIDE

Device	Running Watts
*Air Conditioner (12,000 Btu)	1700
*Air Conditioner (24,000 Btu)	3800
*Air Conditioner (40,000 Btu)	6000
Battery Charger (20 Amp)	500
Belt Sander (3")	1000
Chain Saw	1200
Circular Saw (6-1/2")	.800 to 1000
*Clothes Dryer (Electric)	5750
*Clothes Dryer (Gas)	700
*Clothes Washer	1150
Coffee Maker	1750
*Compressor (1 HP)	2000
*Compressor (3/4 HP)	1800
*Compressor (1/2 HP)	1400
Curling Iron	700
*Dehumidifier	650
Disc Sander (9")	1200
Edge Trimmer	500
Electric Blanket	400

Electric Nail Gun . . . . .	1200
Electric Range (per element) . . . . .	1500
Electric Skillet . . . . .	1250
*Freezer . . . . .	700
*Furnace Fan (3/5 HP) . . . . .	875
*Garage Door Opener . . . . .	.500 to 750
Hair Dryer . . . . .	1200
Hand Drill . . . . .	.250 to 1100
Hedge Trimmer . . . . .	450
Impact Wrench . . . . .	500
Iron . . . . .	1200
*Jet Pump . . . . .	800
Lawn Mower . . . . .	1200
Light Bulb . . . . .	100
Microwave Oven . . . . .	.700 to 1000
*Milk Cooler . . . . .	1100
Oil Burner on Furnace . . . . .	300
Oil Fired Space Heater (140,000 Btu) . . . . .	400
Oil Fired Space Heater (85,000 Btu) . . . . .	225
Oil Fired Space Heater (30,000 Btu) . . . . .	150
*Paint Sprayer, Airless (1/3 HP) . . . . .	600
Paint Sprayer, Airless (handheld) . . . . .	150
Radio . . . . .	.50 to 200
*Refrigerator . . . . .	700
Slow Cooker . . . . .	200
*Submersible Pump (1-1/2 HP) . . . . .	2800
*Submersible Pump (1 HP) . . . . .	2000
*Submersible Pump (1/2 HP) . . . . .	1500
*Sump Pump . . . . .	.800 to 1050
*Table Saw (10") . . . . .	1750 to 2000
Television . . . . .	.200 to 500
Toaster . . . . .	1000 to 1650
Weed Trimmer . . . . .	500

\* Allow 3 times the listed watts for starting these devices.

## 2.7 BEFORE STARTING THE GENERATOR

Prior to operating the generator, engine oil and gasoline will need to be added, as follows:

### 2.7.1 ADDING ENGINE OIL

All oil should meet minimum American Petroleum Institute (API) Service Class SJ, SL or better. Use no special additives. Select the oil's viscosity grade according to the expected operating temperature (also see chart).

- Above 40° F, use SAE 30
- Below 40° F and down to 10° F, use 10W-30
- Below 10° F, use synthetic 5W-30

#### **⚠ WARNING!**

**⚠ Any attempt to crank or start the engine before it has been properly serviced with the recommended oil may result in an engine failure.**

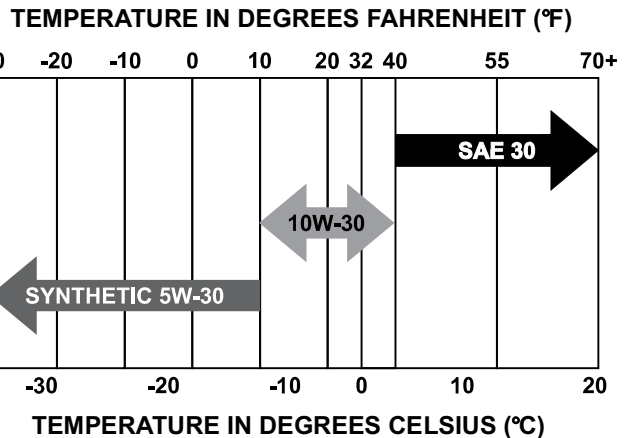

- Place generator on a level surface.
- Clean area around oil fill and remove oil fill cap.
- Slowly fill engine with oil through the oil fill opening until it reaches the full mark. Stop filling occasionally to check oil level. (Engine oil is full when level is up to the threads of the oil fill plug, see Figure 8)
- Install oil fill cap and finger tighten securely.
- Check engine oil level before starting each time thereafter.

**Figure 8 – Oil Level**

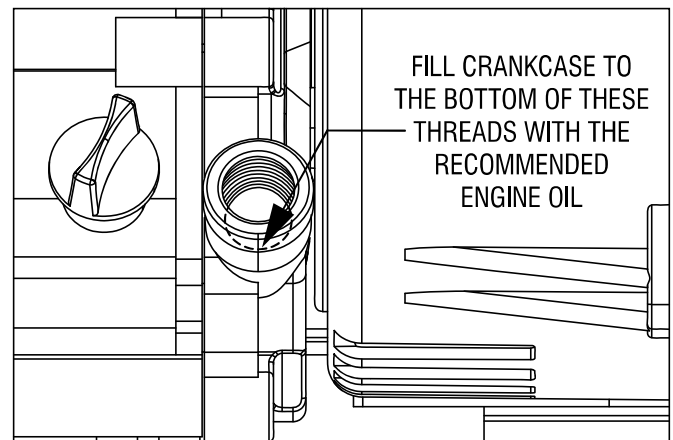

### 2.7.2 ADDING GASOLINE

#### **⚠ DANGER!**

**⚠ DO NOT light a cigarette or smoke when filling the fuel tank.**

**⚠ Never fill fuel tank indoors. Never fill fuel tank when engine is running or hot. Avoid spilling gasoline on a hot engine. Allow engine to cool entirely before filling fuel tank.**

## Operation

**⚠ Do not overfill the fuel tank. Always leave room for fuel expansion. If the fuel tank is overfilled, fuel can overflow onto a hot engine and cause FIRE or EXPLOSION. Wipe up any spilled fuel immediately.**

- Use regular UNLEADED gasoline with the generator engine. Do not use premium gasoline. Do not mix oil with gasoline.
- Do not use gasoline with more than 10% alcohol such as E85 or Methanol.
- Clean area around fuel fill cap, remove cap.
- Slowly add unleaded regular gasoline to fuel tank. Fill to bottom of screen filter. **Be careful not to overfill** (Figure 9).
- Install fuel cap and wipe up any spilled gasoline.

**Figure 9 – Fuel Fill Level**

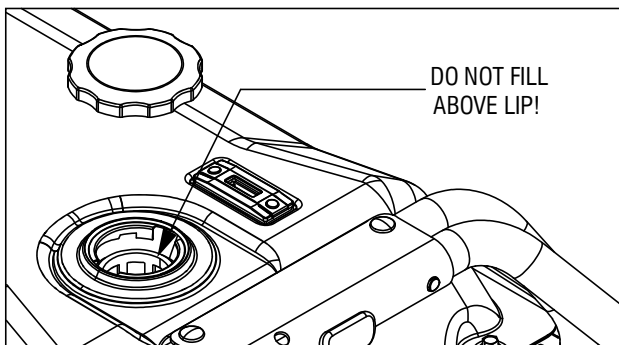

**IMPORTANT:** It is important to prevent gum deposits from forming in fuel system parts such as the carburetor, fuel hose or tank during storage. Alcohol-blended fuels (called gasohol, ethanol or methanol) can attract moisture, which leads to separation and formation of acids during storage. Acidic gas can damage the fuel system of an engine while in storage. To avoid engine problems, the fuel system should be emptied before storage of 30 days or longer. See the "Storage" section. Never use engine or carburetor cleaner products in the fuel tank as permanent damage may occur.

## 2.8 TO START THE ENGINE

**Never start or stop engine with electrical devices plugged into the receptacles AND devices turned on.**

- Unplug all electrical loads from the unit's receptacles before starting the engine.
- Make sure the unit is in a level position.
- Open the fuel shut-off valve (Figure 10).
- Pull engine CHOKE knob outward to "Full Choke" position (Figure 11).

**Figure 10 – Fuel Shut-off Valve**

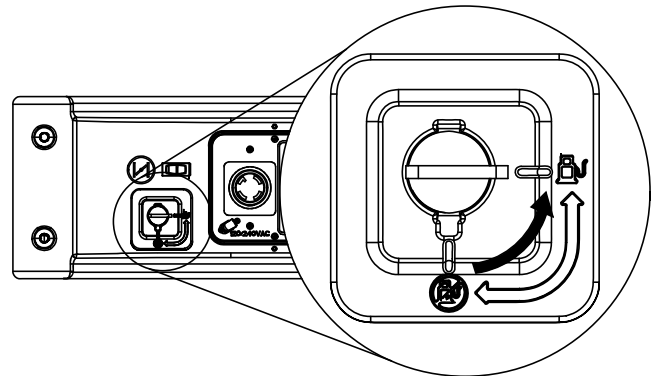

**Figure 11 – Choke Operation**

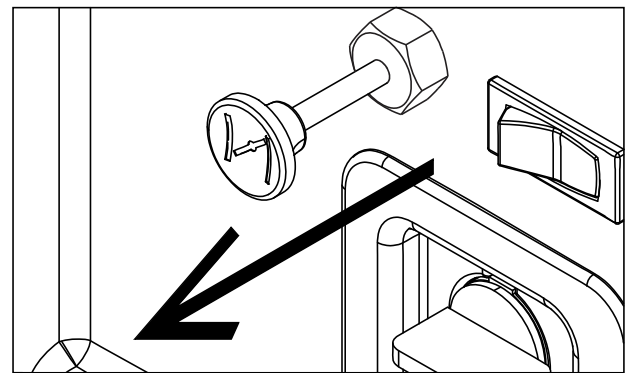

### 2.8.1 MANUAL (RECOIL) STARTING

- To start the generator, put the on/off switch in the ON position.
- Firmly grasp the recoil handle and pull slowly until increased resistance is felt. Pull rapidly up and away to start engine.
- When the engine starts, push choke knob to "1/2 Choke" position until the engine runs smoothly and then fully in to the "Run" position. If engine falters, pull choke knob back out to "1/2 Choke" position until the engine runs smoothly and then to "Run" position.

**NOTE:**

**If engine fires, but does not continue to run, pull choke knob to "Full Choke" and repeat starting instructions.**

**IMPORTANT:** Do not overload the generator. Also, do not overload individual panel receptacles. These outlets are protected against overload with push-to-reset-type circuit breakers. Read "Don't Overload the Generator" carefully.

## 2.8.1 ELECTRIC STARTING (XG7000E & XG8000E)

- To start the engine, press and hold the Start/Run/Stop switch in the “Start” position. The engine will crank and attempt to start. When the engine starts, release the switch to the run position.
- When the engine starts, push choke knob to “1/2 Choke” position until the engine runs smoothly and then fully in to the “Run” position. If engine falters, pull choke knob back out to “1/2 Choke” position until the engine runs smoothly and then to “Run” position.
- This generator is also equipped with a manual recoil starter which may be used if the battery is discharged.

### NOTE:

*The engine Start/Run/Stop switch must be in the RUN position when using the manual recoil starter.*

## 2.9 STOPPING THE ENGINE

- Shut off all loads, then unplug the electrical loads from generator panel receptacles. Never start or stop the engine with electrical devices plugged in and turned on.
- Let engine run at no-load for several minutes to stabilize the internal temperatures of engine and generator.
- Move Start/Run/Stop or On/Off switch to the “Off” position.
- Close fuel valve.

## 2.10 LOW OIL PRESSURE SHUTDOWN SYSTEM

The engine is equipped with a low oil pressure sensor that shuts down the engine automatically when the oil pressure drops below 5 psi. A delay built into the low oil shutdown system allows oil pressure to build during starting. The delay allows the engine to run for about 10 seconds before sensing oil pressure. If the engine shuts down by itself and the fuel tank has enough gasoline, check engine oil level.

### 2.10.1 RESTARTING

If trying to restart the engine within 10 seconds after it shuts down, the engine may NOT start. The system needs 5 to 10 seconds to reset.

If the engine is restarted after such a shutdown and the low oil pressure has not been corrected, the engine will run for about 10 seconds as described above and then stop.

## 2.11 CHARGING THE BATTERY (XG7000E & XG8000E)

### **⚠ DANGER!**

- ⚠ Do not permit smoking, open flame, sparks or any other source of heat around a battery. Wear protective goggles, rubber apron and rubber gloves when working around a battery. Battery electrolyte fluid is an extremely corrosive sulfuric acid solution that can cause severe burns. If spill occurs flush area with clear water immediately.**

**⚠ Storage batteries give off explosive hydrogen gas while recharging. An explosive mixture will remain around the battery for a long time after it has been charged. The slightest spark can ignite the hydrogen and cause an explosion. Such an explosion can shatter the battery and cause blindness or other serious injury.**

Use battery charger plug to keep the battery charged and ready for use. Battery charging should be done in a dry location.

1. Plug charger into “Battery Charger Input” jack, located on the control panel. Plug wall receptacle end of the battery charger into a 120 Volt AC wall outlet.
2. Unplug battery charger from wall outlet and control panel jack when generator is going to be in use.

### NOTE:

**Do not use the battery charger for more than 48 hours at one charge.**

## 3.1 MAINTENANCE SCHEDULE

Follow the calendar intervals. More frequent service is required when operating in adverse conditions noted below.

Check Oil Level	At Each Use
Change Oil and Oil Filter‡	*Every Season/Every 100 Hours
Clean Spark Arrestor Screen	*Every Season/Every 100 Hours
Service Air Cleaner	**Every Season/Every 200 Hours
Replace Spark Plug	Every Season

‡ Change oil after first 30 hours of operation then every season.

\* Change oil and oil filter every month when operating under heavy load or in high temperatures.

\*\* Clean more often under dirty or dusty operating conditions. Replace air cleaner parts if very dirty.

## 3.2 PRODUCT SPECIFICATIONS

### 3.2.1 GENERATOR SPECIFICATIONS

Model #.....	005800-0, 005747-0
Rated Max. Power.....	8.0 kW**
Surge Power.....	10 kW
Rated AC Voltage.....	120/240
Rated Max AC Load	
Current @ 240V.....	33.3 Amps**
Current @ 120V.....	66.7 Amps**
Rated Frequency.....	60 Hz @ 3600 RPM
Phase.....	Single Phase
Rated DC Voltage.....	12 Volts
Battery Type.....	10 AH, 12VDC



**NOTE:**

**DO NOT use a garden hose to clean generator. Water can enter the engine fuel system and cause problems. In addition, if water enters the generator through cooling air slots, some water will be retained in voids and crevices of the rotor and stator winding insulation. Water and dirt buildup on the generator internal windings will eventually decrease the insulation resistance of these windings.**

### 3.3.2 TO CLEAN THE GENERATOR

- Use a damp cloth to wipe exterior surfaces clean.
- A soft, bristle brush may be used to loosen caked on dirt, oil, etc.
- A vacuum cleaner may be used to pick up loose dirt and debris.
- Low pressure air (not to exceed 25 psi) may be used to blow away dirt. Inspect cooling air slots and openings on the generator. These openings must be kept clean and unobstructed.

### 3.3.3 ENGINE MAINTENANCE

**▲ CAUTION!**

**▲ When working on the generator, always disconnect negative cable from battery. Also disconnect spark plug wire from spark plug and keep wire away from spark plug.**

### 3.3.4 CHECKING OIL LEVEL

See the “BEFORE STARTING THE GENERATOR” section for information on checking the oil level. The oil level should be checked before each use, or at least every eight hours of operation. Keep the oil level maintained.

### 3.3.5 CHANGING THE OIL AND OIL FILTER

Change the oil and filter after the first 30 hours of operation. Change the oil every 100 hours or every season thereafter. If running this unit under dirty or dusty conditions, or in extremely hot weather, change the oil more often.

**▲ DANGER!**

**▲ Hot oil may cause burns. Allow engine to cool before draining oil. Avoid prolonged or repeated skin exposure with used oil. Thoroughly wash exposed areas with soap.**

**Use the following instructions to change the oil:**

- Clean area around oil drain cap.
- Remove oil drain cap from the drain hose and oil fill plug to drain oil completely into a suitable container.
- When oil has completely drained, install oil drain cap and tighten securely.
- Place a suitable container beneath the oil filter and turn filter counterclockwise to remove. Discard according to local regulations.

- Coat gasket of new filter with clean engine oil. Turn filter clockwise until gasket contacts lightly with filter adapter. Then tighten an additional 3/4 turn.
- Fill oil sump with recommended oil and replace the oil fill plug. (See “Before Starting the Generator” for oil recommendations).
- Wipe up any spilled oil.
- Dispose of used oil at a proper collection center.

### 3.3.6 REPLACING THE SPARK PLUG

Use Champion RC14YC spark plug or equivalent. **Replace the plug once each year.** This will help the engine start easier and run better.

1. Stop the engine and pull the spark plug wire off of the spark plug.
2. To gain access, remove the four (4) socket head screws and take off the side panel.
3. Clean the area around the spark plug and remove it from the cylinder head.
4. Set the spark plug's gap to .76 mm (0.030 in.). Install the correctly gapped spark plug into the cylinder head (Figure 12).
5. Push the boot firmly on the spark plug and install side panel.

**Figure 12 – Spark Plug Gap**

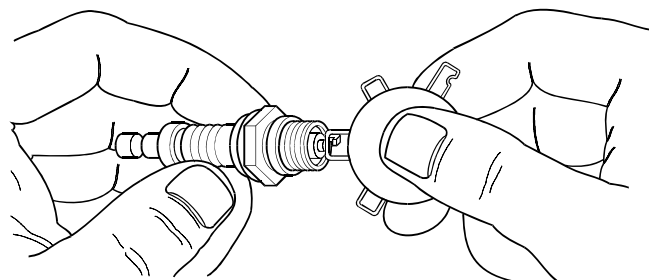

### 3.4 SERVICE AIR CLEANER

The engine will not run properly and may be damaged if using a dirty air cleaner. Clean or replace the air cleaner paper filter every 200 hours or once a year (Figure 15). Clean or replace more often if operating under dusty conditions. To clean or replace paper air filter:

- Remove air cleaner cover and remove paper filter (Figure 13).
- Clean paper filter by tapping it gently on a solid surface. If the filter is too dirty, replace it with a new one. Dispose of the old filter properly.
- Clean air cleaner cover. Next insert new paper filter into the base of the air cleaner. Re-install air cleaner cover.

**NOTE:**

**To order a new air filter, please contact the nearest authorized service center at 1-888-GENERAC.**



Figure 13 – Air Filter

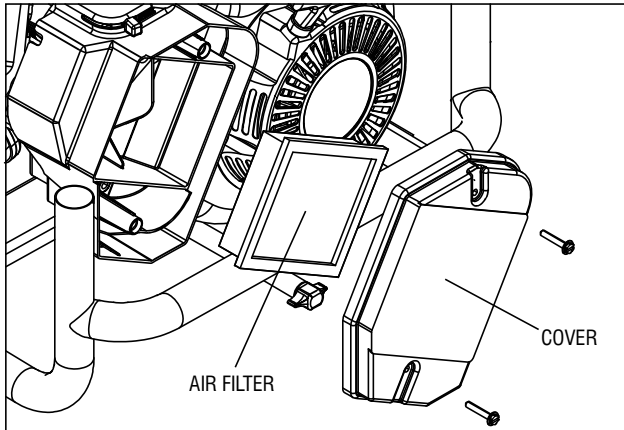

## 3.5 CLEAN SPARK ARRESTOR SCREEN

The engine exhaust muffler has a spark arrestor screen. Inspect and clean the screen at least once each year (Figure 14). If unit is used regularly, inspect and clean more often.

### ⚠ DANGER!

- ⚠ If using the generator on any forest-covered, brush-covered or grass-covered unimproved land, it must be equipped with a spark arrestor. The spark arrestor must be maintained in good condition by the owner/operator.

Clean and inspect the spark arrestor when the engine is at ambient temperature as follows:

- Loosen the clamp and remove the spark arrestor screen from the muffler.
- Inspect screen and replace if torn, perforated or otherwise damaged. DO NOT USE a defective screen. If screen is not damaged, clean it with commercial solvent.
- Replace the spark arrestor and secure with the clamp.

Figure 14 – Spark Arrestor Screen

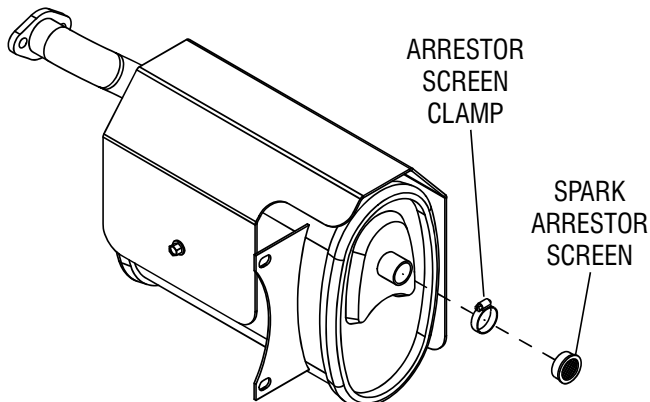

## 3.6 GENERAL

The generator should be started at least once every seven days and be allowed to run at least 30 minutes. If this cannot be done and the unit must be stored for more than 30 days, use the following information as a guide to prepare it for storage.

### ⚠ DANGER!

- ⚠ NEVER store engine with fuel in tank indoors or in enclosed, poorly ventilated areas where fumes may reach an open flame, spark or pilot light as on a furnace, water heater, clothes dryer or other gas appliance.

- ⚠ Allow unit to cool entirely before storage.

## 3.7 LONG TERM STORAGE

It is important to prevent gum deposits from forming in essential fuel system parts such as the carburetor, fuel hose or tank during storage. To avoid engine problems, the fuel system should be emptied before storage of 30 days or longer, as follows:

- Remove all gasoline from the fuel tank.

### ⚠ CAUTION!

- ⚠ Drain fuel into approved container outdoors, away from open flame. Be sure engine is cool. Do not smoke in the vicinity or light a cigarette.

- Start and run engine until engine stops from lack of fuel.
- Allow the engine to cool, then drain oil from crankcase. Refill with recommended grade.
- Remove spark plug and pour about 1/2 ounce (15 ml) of engine oil into the cylinder. Cover spark plug hole with rag. Pull the recoil starter a couple times to lubricate the piston rings and cylinder bore.

### ⚠ CAUTION!

- ⚠ Avoid spray from spark plug hole when cranking engine.

- Install and tighten spark plug. Do not connect the spark plug wire.
- Clean the generator outer surfaces. Check that cooling air slots and openings on generator are open and unobstructed.
- Store the unit in a clean, dry place.

## 3.8 OTHER STORAGE TIPS

- Do not store gasoline from one season to another.
- Replace any gasoline can that starts to rust. Rust and/or dirt in the gasoline will cause problems with the carburetor and fuel system.
- If possible, store the unit indoors and cover it to give protection from dust and dirt. Cover the unit with a suitable protective cover that does not retain moisture.
- **BE SURE TO EMPTY THE FUEL TANK.** If it is not practical to empty the fuel tank and the unit is to be stored for some time, use a commercially available fuel stabilizer added to the gasoline to increase the life of the gasoline.

### ▲ CAUTION!

**! NEVER cover the generator while engine and exhaust area are warm.**

## 4.1 BATTERY REPLACEMENT (XG7000E & XG8000E)

### NOTE:

The battery shipped with the generator has been fully charged. A battery may lose some of its charge when not in use for prolonged periods of time. If the battery is unable to crank the engine, plug in the 12V charger included in the accessory box (see the Charging a Battery section). **RUNNING THE GENERATOR DOES NOT CHARGE THE BATTERY.**

The battery shipped with the generator has been provided fully charged. To replace the battery (See Figure 16):

- Remove the side panel as shown. Remove the four bolts securing the fuel tank.
- Turn the fuel valve on the control panel to the "OFF" position. Pull the fuel tank back slightly and remove the fuel hose that runs from the engine to the fuel valve.

### ▲ CAUTION!

**! Drain fuel into approved container outdoors, away from open flame. Be sure engine is cool. Do not smoke in the vicinity or light a cigarette.**

- Push the fuel valve from the control panel and remove the fuel tank.
- Remove the battery wire connections (black wire first) and the battery hold-down bracket.
- Replace the battery, connecting the RED wire to the POSITIVE (+) terminal and the BLACK wire to the NEGATIVE (-) terminal

### NOTE:

**Start all four screws on the side panel before tightening or it may not be possible to get all the screws in place.**

Figure 16 – Battery Removal

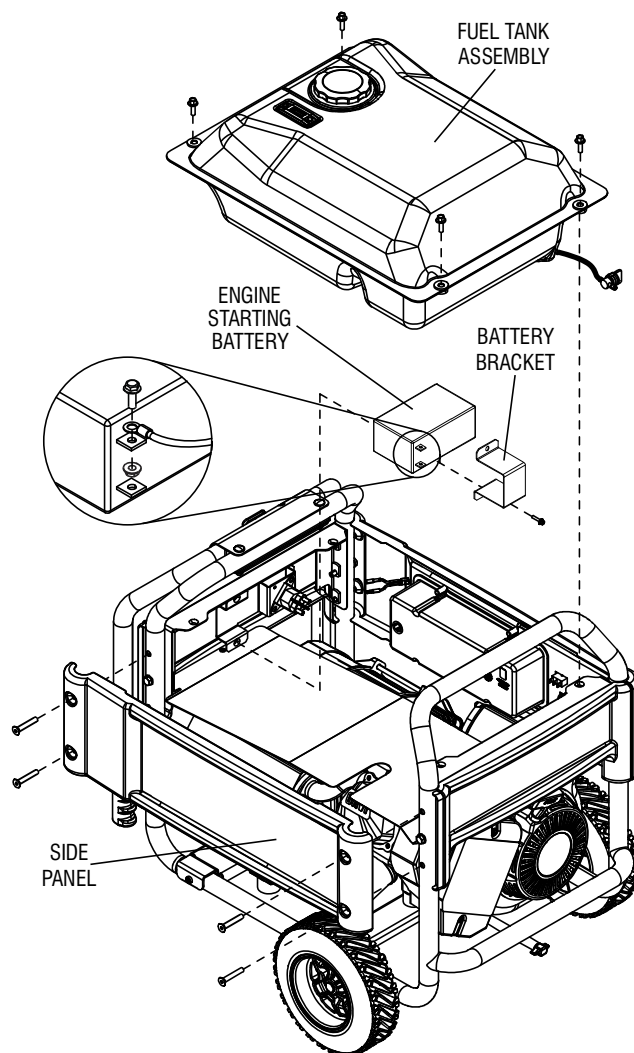

# Troubleshooting

## 5.1 TROUBLESHOOTING GUIDE

PROBLEM	CAUSE	CORRECTION
Engine is running, but no AC output is available.	<ol style="list-style-type: none"> <li>1. Circuit breaker is open.</li> <li>2. Poor connection or defective cord set.</li> <li>3. Connected device is bad.</li> <li>4. Fault in generator.</li> <li>5. GFCI trips the 20 Amp outlet.</li> </ol>	<ol style="list-style-type: none"> <li>1. Reset circuit breaker.</li> <li>2. Check and repair.</li> <li>3. Connect another device that is in good condition.</li> <li>4. Contact Authorized Service Facility.</li> <li>5. Repair the "short" and reset the GFCI.</li> </ol>
Engine runs good but bogs down when loads are connected.	<ol style="list-style-type: none"> <li>1. Short circuit in a connected load.</li> <li>2. Generator is overloaded.</li> <li>3. Engine speed is too slow.</li> <li>4. Shorted generator circuit.</li> </ol>	<ol style="list-style-type: none"> <li>1. Disconnect shorted electrical load.</li> <li>2. See "Don't Overload the Generator" .</li> <li>3. Contact Authorized Service Facility.</li> <li>4. Contact Authorized Service Facility.</li> </ol>
Engine will not crank.	<ol style="list-style-type: none"> <li>1. Battery weak or dead.</li> </ol>	<ol style="list-style-type: none"> <li>1. Recharge or replace battery (see "No Battery Charger DC output" at bottom of guide).</li> <li>2. Start engine manually using recoil starter.</li> </ol>
Engine will not start; or starts and runs rough.	<ol style="list-style-type: none"> <li>1. Fuel shut-off is OFF.</li> <li>2. Dirty air cleaner.</li> <li>3. Out of gasoline.</li> <li>4. Stale gasoline.</li> <li>5. Spark plug wire not connected to spark plug.</li> <li>6. Bad spark plug.</li> <li>7. Water in gasoline.</li> <li>8. Over-choking.</li> <li>9. Low oil level.</li> <li>10. Excessive rich fuel mixture.</li> <li>11. Intake valve stuck open or closed.</li> <li>12. Engine has lost compression.</li> </ol>	<ol style="list-style-type: none"> <li>1. Turn Fuel shut-off ON.</li> <li>2. Clean or replace air cleaner.</li> <li>3. Fill fuel tank.</li> <li>4. Drain fuel tank and fill with fresh fuel.</li> <li>5. Connect wire to spark plug.</li> <li>6. Replace spark plug.</li> <li>7. Drain fuel tank; fill with fresh fuel.</li> <li>8. Put choke knob to <b>No Choke</b> position.</li> <li>9. Fill crankcase to proper level.</li> <li>10. Contact Authorized Service Facility.</li> <li>11. Contact Authorized Service Facility.</li> <li>12. Contact Authorized Service Facility.</li> </ol>
Engine shuts down during operation.	<ol style="list-style-type: none"> <li>1. Out of gasoline.</li> <li>2. Low oil level.</li> <li>3. Fault in engine.</li> </ol>	<ol style="list-style-type: none"> <li>1. Fill fuel tank.</li> <li>2. Fill crankcase to proper level.</li> <li>3. Contact Authorized Service Facility.</li> </ol>
Engine lacks power.	<ol style="list-style-type: none"> <li>1. Load is too high.</li> <li>2. Dirty air filter.</li> <li>3. Engine needs to be serviced.</li> </ol>	<ol style="list-style-type: none"> <li>1. See "Don't Overload the Generator".</li> <li>2. Replace air filter.</li> <li>3. Contact Authorized Service Facility.</li> </ol>
Engine "hunts" or falters.	<ol style="list-style-type: none"> <li>1. Choke is opened too soon.</li> <li>2. Carburetor is running too rich or too lean.</li> </ol>	<ol style="list-style-type: none"> <li>1. Move choke to halfway position until engine runs smoothly.</li> <li>2. Contact Authorized Service Facility.</li> </ol>
No Battery Charger DC output.	<ol style="list-style-type: none"> <li>1. Battery posts are corroded.</li> <li>2. Battery cable is bad.</li> <li>3. Battery is defective.</li> <li>4. Receptacle is bad.</li> <li>5. Battery Charger in-line fuse (1.5A) melted open.</li> </ol>	<ol style="list-style-type: none"> <li>1. Clean battery posts.</li> <li>2. Replace cable.</li> <li>3. Check battery condition; replace if defective.</li> <li>4. Contact Authorized Service Facility.</li> <li>5. Replace fuse with identical 1.5A replacement fuse only (located inside control panel).</li> </ol>



## CALIFORNIA AND FEDERAL EMISSION CONTROL WARRANTY STATEMENT YOUR WARRANTY RIGHTS AND OBLIGATIONS

The California Air Resources Board (CARB) and the United States Environmental Protection Agency (EPA), together with Generac Power Systems, Inc. (Generac), are pleased to explain the Emission Control System warranty on your new 2008 and later generator. New equipment that use small spark-ignited engines must be designed, built, and equipped to meet stringent anti-smog standards for the state of California and the federal government. Generac will warrant the emission control system on your generator for the period of time listed below provided there has been no abuse, neglect, unapproved modification or improper maintenance of your equipment.

Your emission control system may include parts such as the: carburetor, ignition system, catalytic converter, fuel tank, fuel lines, fuel cap, valves, carbon canister, filters, vapor hoses, clamps, connectors, and other associated emission-related components (if equipped).

### MANUFACTURER'S WARRANTY COVERAGE:

This emission control system is warranted for two years. If, during such warranty period, any emission-related part on your equipment is found to be defective in materials or workmanship, repairs or replacement will be performed by a Generac Authorized Warranty Service Dealer.

### OWNER'S WARRANTY RESPONSIBILITIES:

As the generator owner, you are responsible for the completion of all required maintenance as listed in your factory supplied Owner's Manual. For warranty purposes, Generac recommends that you retain all receipts covering maintenance on your generator, but Generac cannot deny warranty solely due to the lack of receipts.

As the generator owner, you should be aware that Generac may deny any and/or all warranty coverage or responsibility if your generator, or a part/component thereof, has failed due to abuse, neglect, improper maintenance or unapproved modifications, or the use of counterfeit and/or "grey market" parts not made, supplied or approved by Generac.

**You are responsible for contacting a Generac Authorized Warranty Dealer as soon as a problem occurs. The warranty repairs should be completed in a reasonable amount of time, not to exceed 30 days.**

Warranty service can be arranged by contacting either your selling dealer or a Generac Authorized Warranty Service Dealer. To locate the Generac Authorized Warranty Service Dealer nearest you, call our toll free number:

**1-800-333-1322**

**IMPORTANT NOTE:** This warranty statement explains your rights and obligations under the Emission Control System Warranty (ECS Warranty), which is provided to you by Generac pursuant to California and federal law. See also the "Generac Limited Warranties for Generac Power Systems, Inc.," which is enclosed herewith on a separate sheet, also provided to you by Generac. Note that this warranty shall not apply to any incidental, consequential or indirect damages caused by defects in materials or workmanship or any delay in repair or replacement of the defective part(s). This warranty is in place of all other warranties, expressed or implied. Specifically, Generac makes no other warranties as to the merchantability or fitness for a particular purpose. Some states do not allow limitations on how long an implied warranty lasts, so the above limitation may not apply to you.

The ECS Warranty applies **only** to the emission control system of your new equipment. If there is any conflict in terms between the ECS Warranty and the Generac Warranty, the Generac Warranty shall apply. Both the ECS Warranty and the Generac Warranty describe important rights and obligations with respect to your new engine.

Warranty service can be performed only by a Generac Authorized Warranty Service Facility. When requesting warranty service, evidence must be presented showing the date of the sale to the original purchaser/owner.

If you have any questions regarding your warranty rights and responsibilities, you should contact Generac at the following address:

**ATTENTION WARRANTY DEPARTMENT  
GENERAC POWER SYSTEMS, INC.  
P.O. BOX 297 • WHITEWATER, WI 53190**

**EMISSION CONTROL SYSTEM WARRANTY**

Emission Control System Warranty (ECS warranty) for equipment using small spark-ignited engines:

- (a) **Applicability:** This warranty shall apply to equipment that uses small off-road engines. The ECS Warranty period shall begin on the date the new equipment is purchased by/delivered to its original, end-use purchaser/owner and shall continue for 24 consecutive months thereafter.
- (b) **General Emissions Warranty Coverage:** Generac warrants to the original, end-use purchaser/owner of the new engine or equipment and to each subsequent purchaser/owner that the ECS when installed was:
  - (1) Designed, built and equipped so as to conform with all applicable regulations; and
  - (2) Free from defects in materials and workmanship which cause the failure of a warranted part at any time during the ECS Warranty Period.
- (c) The warranty on emissions-related parts will be interpreted as follows:
  - (1) Any warranted part that is not scheduled for replacement as required maintenance in the Owner's Manual shall be warranted for the ECS Warranty Period. If any such part fails during the ECS Warranty Period, it shall be repaired or replaced by Generac according to Subsection (4) below. Any such part repaired or replaced under the ECS Warranty shall be warranted for the remainder of the ECS Warranty Period.
  - (2) Any warranted part that is scheduled only for regular inspection as specified in the Owner's Manual shall be warranted for the ECS Warranty Period. A statement in the Owner's Manual to the effect of "repair or replace as necessary" shall not reduce the ECS Warranty Period. Any such part repaired or replaced under the ECS Warranty shall be warranted for the remainder of the ECS Warranty Period.
  - (3) Any warranted part that is scheduled for replacement as required maintenance in the Owner's Manual shall be warranted for the period of time prior to first scheduled replacement point for that part. If the part fails prior to the first scheduled replacement, the part shall be repaired or replaced by Generac according to Subsection (4) below. Any such emissions-related part repaired or replaced under the ECS warranty shall be warranted for the remainder of the period prior to the first scheduled replacement point for that part.
  - (4) Repair or replacement of any warranted, emissions-related part under this ECS Warranty shall be performed at no charge to the owner at a Generac Authorized Warranty Service Facility.
  - (5) Notwithstanding the provisions of subsection (4) above, warranty services or repairs must be provided at Generac Authorized Service Facilities.
  - (6) When the engine is inspected by a Generac Authorized Warranty Service Facility, the purchaser/owner shall not be held responsible for diagnostic costs if the repair is deemed warrantable.
  - (7) Throughout the ECS Warranty Period, Generac shall maintain a supply of warranted emission-related parts sufficient to meet the expected demand for such parts.
  - (8) Any Generac authorized and approved emission-related replacement parts may be used in the performance of any ECS warranty maintenance or repairs and will be provided without charge to the purchaser/owner. Such use shall not reduce Generac ECS Warranty obligations.
  - (9) Unapproved, add-on, modified, counterfeit and/or "grey market" parts may not be used to modify or repair a Generac engine. Such use voids this ECS Warranty and shall be sufficient grounds for disallowing an ECS Warranty claim. Generac shall not be held liable hereunder for failures of any warranted parts of Generac equipment caused by the use of such an unapproved, add-on, modified, counterfeit and/or "grey market" part.

**EMISSION RELATED PARTS MAY INCLUDE THE FOLLOWING (IF EQUIPPED):**

- |   |  |
|---|--|
| <ol style="list-style-type: none"> <li>1) FUEL SYSTEM               <ol style="list-style-type: none"> <li>A. FUEL TANK</li> <li>B. FUEL CAP</li> <li>C. FUEL LINE</li> <li>D. FUEL LINE FITTINGS</li> <li>E. CLAMPS*</li> <li>F. PRESSURE RELIEF VALVES*</li> </ol> </li> <li>2) EVAPORATIVE CONTROL SYSTEM               <ol style="list-style-type: none"> <li>A. CARBON CANISTER</li> <li>B. CANISTER MOUNTING BRACKETS</li> <li>C. CARBURETOR PURGE PORT</li> <li>D. CONTROL VALVES*</li> <li>E. VAPOR HOSES</li> <li>F. PURGE VALVES</li> <li>G. LIQUID / VAPOR SEPARATOR</li> <li>H. VACUUM CONTROL DIAPHRAGMS*</li> </ol> </li> </ol> | <ol style="list-style-type: none"> <li>3) FUEL METERING SYSTEM               <ol style="list-style-type: none"> <li>A. CARBURETOR AND INTERNAL PARTS</li> <li>B. PRESSURE REGULATOR</li> </ol> </li> <li>4) AIR INDUCTION SYSTEM               <ol style="list-style-type: none"> <li>A. INTAKE MANIFOLD</li> <li>B. AIR FILTER</li> </ol> </li> <li>5) IGNITION SYSTEM               <ol style="list-style-type: none"> <li>A. SPARK PLUGS</li> <li>B. IGNITION COILS / MODULE</li> </ol> </li> <li>6) AIR INJECTION SYSTEM               <ol style="list-style-type: none"> <li>A. PULSE AIR VALVE</li> </ol> </li> <li>7) EXHAUST SYSTEM               <ol style="list-style-type: none"> <li>A. CATALYST</li> <li>B. THERMAL REACTOR</li> <li>C. EXHAUST MANIFOLD</li> </ol> </li> </ol> |
|---|--|

\*NOTE: As they relate to the Emission Control System.

# Warranty

## GENERAC POWER SYSTEMS "TWO YEAR" LIMITED WARRANTY FOR XG SERIES PORTABLE GENERATORS

For a period of two years from the date of original sale, Generac Power Systems, Inc. (Generac) warrants its XG Series generators will be free from defects in materials and workmanship for the items and period set forth below. Generac will, at its option, repair or replace any part which, upon examination, inspection and testing by Generac or a Generac Authorized Warranty Service Dealer, is found to be defective. Any equipment that the purchaser/owner claims to be defective must be returned to and examined by the nearest Generac Authorized Warranty Service Dealer. All transportation costs under the warranty, including return to the factory, are to be borne and prepaid by the purchaser/owner. This warranty applies only to Generac XG Series portable generators and is not transferable from original purchaser. Save your proof-of-purchase receipt. If you do not provide proof of the initial purchase date, the manufacturer's shipping date of the product will be used to determine the warranty period.

### WARRANTY SCHEDULE

Consumer applications are warranted for two (2) years. Commercial and Rental applications are warranted for one (1) year or 1000 hours maximum, whichever comes first.

#### CONSUMER APPLICATION

YEAR ONE - 100% (one hundred percent) coverage on Labor and Part(s) (proof of purchase and maintenance is required):

- All Components

YEAR TWO- 100% (one hundred percent) coverage on Part(s) (proof of purchase and maintenance is required):

- All Components

#### COMMERCIAL/RENTAL APPLICATION

YEAR ONE – 100% (one hundred percent) coverage on Labor and Part(s) (proof of purchase and maintenance is required):

- All Components

**NOTE:** For the purpose of this warranty "consumer use" means personal residential household or recreational use by original purchaser. This warranty does not apply to units used for Prime Power in place of utility where utility power service is present or where utility power service does not normally exist. Once a generator has experienced commercial or rental use, it shall thereafter be considered a non-consumer use generator for the purpose of this warranty.

All warranty expense allowances are subject to the conditions defined in Generac's Warranty Policies, Procedures and Flat Rate Manual.

### THIS WARRANTY SHALL NOT APPLY TO THE FOLLOWING:

- Generac portable generators that utilize non-Generac replacement parts.
- Costs of normal maintenance and adjustments.
- Failures caused by any contaminated fuels, oils or lack of proper oil levels.
- Repairs or diagnostics performed by individuals other than Guardian/Generac authorized dealers not authorized in writing by Generac Power Systems.
- Failures due, but not limited, to normal wear and tear, accident, misuse, abuse, negligence or improper use. As with all mechanical devices, the Generac engines need periodic part(s) service and replacement to perform as designed. This warranty will not cover repair when normal use has exhausted the life of a part(s) or engine.
- Failures caused by any act of God and other force majeure events beyond the manufacturer's control.
- Damage related to rodent and/or insect infestation.
- Products that are modified or altered in a manner not authorized by Generac in writing.
- Any incidental, consequential or indirect damages caused by defects in materials or workmanship, or any delay in repair or replacement of the defective part(s).
- Failure due to misapplication.
- Telephone, cellular phone, facsimile, internet access or other communication expenses.
- Living or travel expenses of person(s) performing service, except as specifically included within the terms of a specific unit warranty period.
- Expenses related to "customer instruction" or troubleshooting where no manufacturing defect is found.
- Rental equipment used while warranty repairs are being performed.
- Overnight freight or special shipping costs for replacement part(s).
- Overtime, holiday or emergency labor.
- Starting batteries, fuses, filters, light bulbs and engine fluids.

THIS WARRANTY IS IN PLACE OF ALL OTHER WARRANTIES, EXPRESSED OR IMPLIED, SPECIFICALLY, GENERAC POWER SYSTEMS MAKES NO OTHER WARRANTIES AS TO THE MERCHANTABILITY OR FITNESS FOR A PARTICULAR PURPOSE. Any implied warranties which are allowed by law, shall be limited in duration to the terms of the express warranty provided herein. Some states do not allow limitations on how long an implied warranty lasts, so the above limitation may not apply to purchaser/owner.

GENERAC POWER SYSTEMS ONLY LIABILITY SHALL BE THE REPAIR OR REPLACEMENT OF PART(S) AS STATED ABOVE. IN NO EVENT SHALL GENERAC POWER SYSTEMS BE LIABLE FOR ANY INCIDENTAL, OR CONSEQUENTIAL DAMAGES, EVEN IF SUCH DAMAGES ARE A DIRECT RESULT OF GENERAC POWER SYSTEMS, INC. NEGLIGENCE. Some states do not allow the exclusion or limitation of incidental or consequential damages, so the above limitations may not apply to purchaser/owner. Purchaser/owner agrees to make no claims against Generac Power Systems, Inc. based on negligence. This warranty gives purchaser/owner specific legal rights. Purchaser/owner also may have other rights that vary from state to state.

**GENERAC POWER SYSTEMS, INC.**  
**P.O. BOX 8 • Waukesha, WI 53187**

**Ph: (888) GENERAC (436-3722) • Fax: (262) 544-4851**

**To locate the nearest Authorized Dealer visit our website [www.generac.com](http://www.generac.com)**